



VERTICAL XPRESS VX425

OPERATION MANUAL PARTS MANUAL

ROTO-MIX

A division of JSI Industries Inc.

P.O. BOX 1724

2205 E. Wyatt Earp Blvd.

Dodge City, Kansas 67801

(620) 225-1142

SERIAL NUMBER _____

TABLE OF CONTENTS

	PAGE NO.
WARRANTY.....	1
OPERATOR QUALIFICATIONS.....	2
SAFETY.....	3-14
LOADING INSTRUCTIONS.....	15
LUBRICATION.....	17
MAINTENANCE & LUBRICATION.....	16
REPAIR PARTS CONTENT PAGE.....	17

WARRANTY

ROTO-MIX, (A division of JSI Industries, Inc.), warrants to the original purchaser all products manufactured by it to be free from defects in material and workmanship under normal use and service. ROTO-MIX's obligation under this warranty is limited to repairing or replacing, as the company may elect, free of charge and without charge for installation, at the place of business of a dealer or distributor authorized to handle the equipment covered by this warranty or at a ROTO-MIX plant, any parts that prove, in the company's judgment, to be defective in material and workmanship within one (1) year after delivery to the original purchaser, and still owned by the original purchaser.

It is a condition of this warranty that the original purchaser must fill out the warranty card furnished by ROTO-MIX and that it be returned to ROTO-MIX and be recorded in ROTO-MIX's owner file for this warranty to be valid. In the event an owner's card is not on file at the ROTO-MIX office, the warranty period will extend only from date equipment was picked up or delivered from the ROTO-MIX plant.

It is a condition of this warranty that if within a aforesaid period of time, said equipment, product or parts are determined by the original purchaser to be defective as herein provided, then such defective part or parts must be delivered by or through a dealer and/or distributor to ROTO-MIX at its factory with transportation prepaid or warranty shall be of no force or effect and shall be waived by the purchaser. If ROTO-MIX, or its duly authorized representative, shall find that such returned part or parts are defective and such defects, or defect, are included in and covered by said warranty, then such defective part or parts shall promptly be replaced without charge to the purchaser, F.O.B. the ROTO-MIX plant.

This warranty shall not apply to any item, manufactured in whole or in part by ROTO-MIX, which shall have been operated in a manner not recommended by ROTO-MIX nor which shall have been repaired, altered, neglected, tampered with, or used in anyway which in the company's opinion adversely affects its performance.

This warranty shall in no way make ROTO-MIX liable to anyone for personal injuries or damages, loss of time, or expense of any kind either direct or indirect resulting from part failure or defect.

This warranty is subject to acts of God, fire and existing conditions of supply and demand, or production, or ability or inability to deliver, or for any other valid reason beyond the reasonable control of ROTO-MIX, to obtain materials, manufactured replacement parts, or make delivery thereof.

No distributor, dealer, agent, or employee of ROTO-MIX is authorized to extend any other or further express or implied warranty or incur any additional obligation on ROTO-MIX's behalf in connection with the sale of this product.

ROTO-MIX reserves the right to make changes in design, or additions to, or improvements in its equipment without obligation to install such changes, additions, or improvements in equipment previously manufactured.

OPERATOR QUALIFICATIONS

Operation Of this mixer/feeder shall be limited to competent and experienced persons. In addition, anyone who will operate or work around a mixer/feeder must use good common sense. In order to be qualified, he or she must also know and meet all other qualifications, such as:

1. Some regulations specify that no one under the age of sixteen (16) may operate power machinery. It is your responsibility to know what these regulations are in your area and/or situation.
2. Current OSHA regulations state in part: At the time of initial assignment and at least annually thereafter, the employer shall instruct **EVERY** employee in the safe operation and servicing of all equipment with which the employee is, or will be involved.
3. Unqualified persons are to **STAY OUT OF THE WORK AREA.**
4. A person who has not read and understood all operating and safety instructions is not qualified to operate the machinery.

FAILURE TO READ THIS MIXER/FEEDER MANUAL AND ITS SAFETY INSTRUCTIONS IS A MISUSE OF THE EQUIPMENT.



SAFETY

TAKE NOTE! THIS SAFETY ALERT SYMBOL FOUND THROUGHOUT THIS MANUAL IS USED TO CALL YOUR ATTENTION TO INSTRUCTIONS INVOLVING YOUR PERSONAL SAFETY AND THE SAFETY OF OTHERS. FAILURE TO FOLLOW THESE INSTRUCTIONS CAN RESULT IN INJURY OR DEATH.



THIS SYMBOL MEANS

-ATTENTION!

-BECOME ALERT!

-YOUR SAFETY IS INVOLVED!

SIGNAL WORDS: Note the use of the signal words **DANGER**, **WARNING**, and **CAUTION** with the safety messages. The appropriate signal word for each has been selected using the following guidelines:

DANGER: Indicates an imminently hazardous situation that, if not avoided, will result in serious injury or death. This signal word is to be limited to the most extreme situations typically for machine components which, for functional purposes, cannot be guarded.

WARNING: Indicates a potentially hazardous situation that, if not avoided, will result in serious injury or death, and includes hazards that are exposed when guards are removed. It may also be used to alert against unsafe practices.

CAUTION: Indicates a potentially hazardous situation that, if not avoided, may result in minor or moderate injury. It may also be used to alert against unsafe practices.

If you have questions not answered in this manual or require additional copies or the manual is damaged, please contact your dealer or ROTO-MIX, 2205 E. Wyatt Earp, Dodge City, Kansas, 67801. (Telephone) 620-225-1142 (Fax) 620-225-6370

SAFETY FIRST

REMEMBER: The careful operator is the best operator. Most accidents are caused by human error. Certain precautions must be observed to prevent the possibility of injury or death.



DO NOT ALLOW PERSONNEL OTHER THAN THE QUALIFIED OPERATOR NEAR THE MACHINE.



NEVER START MACHINE UNTIL ALL GUARDS AND SAFETY SHIELDS ARE IN PLACE.



DO NOT CLEAN, ADJUST OR LUBRICATE THE MACHINE WHILE IT IS IN MOTION.



BEFORE STARTING TRACTOR ENGINE, BE SURE PTO SHIELDS TURN FREELY.



LOOSE OR FLOPPY CLOTHING SHOULD NOT BE WORN BY THE OPERATOR.

OPERATING PRECAUTIONS & INSTRUCTIONS:

- A. Check to see that no obstructions are present in the mixer prior to start up.
- B. Before loading, run the mixer empty and check all operations.
- C. Do not overload the mixer. Maximum load is determined by weight, not volume.
- D. Be sure all shields are in place before operation.
- E. Use common sense when operating.



EQUIPMENT SAFETY GUIDELINES

Safety of the operator is one of the main concerns in designing and developing a new piece of equipment. Designers and manufactures build in as many safety features as possible. However, every year many accidents occur which could have been avoided by a few seconds of thought and a more careful approach to handling equipment. You, the operator, can avoid many accidents by observing the following precautions in this section. To avoid personal injury, study the following precautions and insist those working with you, or for you, follow them.

In order to provide a better view, certain photographs or illustrations in this manual may show an assembly with a safety shield removed. However, equipment should never be operated in this condition. Keep all shields in place. If shield removal becomes necessary for repairs, replace the shield prior to use.

Replace any CAUTION, WARNING, DANGER or instruction safety decal that is not readable or is missing. Location of such decals are indicated in this manual.

Do not attempt to operate this equipment under the influence of drugs or alcohol.

Review the safety instructions with all users annually.

This equipment is dangerous to children and persons unfamiliar with its operation. The operator should be a responsible adult familiar with farm machinery and trained in this equipment's operations. Do not allow persons to operate or assemble this unit until they have read this manual and have developed a thorough understanding of the safety precautions and of how it works.

To prevent injury or death, use a tractor equipped with a Roll Over Protective System (ROPS). Do not paint over, remove or deface any safety signs or warning decals on your equipment. Observe all safety signs and practice the instructions on them.

Never exceed the limits of a piece of machinery, in its ability to do a job, or to do so safely, if in question - **DON'T TRY IT.**



LIGHTING AND MARKING

It is the responsibility of the customer to know the lighting and marking requirements of the local highway authorities and to install and maintain the equipment to provide compliance with the regulations. Add extra lights when transporting at night or during periods of limited visibility.



KEEP ALL SHIELDS IN PLACE

Do not operate mixer/feeder without safety shields in place.

Rotating parts can crush or dismember causing personal injury or death.

Disconnect PTO driveline before removing shields for adjustment or service.

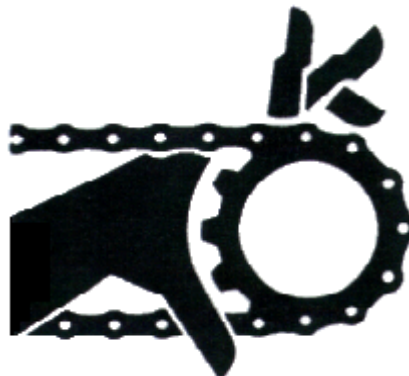

OPERATE MIXER/FEEDER SAFELY

Rotating parts can entangle or strike people, resulting in personal injury or death.

Never enter a mixer/feeder while in operation.

Operate the mixer/feeder from the operator's seat only.

Do not exceed load capacity of the mixer/feeder. (See loading instructions).

Reduce speed when turning or traveling on rough terrain.

Avoid traveling over loose fill, rocks, ditches or holes.

Keep transmissions in gear when traveling downhill.



KEEP RIDERS OFF MIXER/FEEDER

Keep riders off.

Riders are subject to injury such as being struck by foreign objects and being thrown off. Riders also obstruct the operator's view resulting in the machine being operated in an unsafe manner.





STAY CLEAR OF ROTATING DRIVELINES

Entanglement in rotating driveline can cause serious injury or death.

Keep tractor master shield and driveline shields in place at all times. Make sure rotating shields turn freely.

Wear close fitting clothing. Stop the engine and be sure PTO driveline is stopped before making adjustments, connections, or cleaning out PTO driven equipment .



PREVENT BATTERY EXPLOSIONS

Keep sparks, lighted matches, and open flame away from the top of battery. Battery gas can explode.

Never check battery charge by placing a metal object across the posts. Use a volt-meter or hydrometer.

Do not charge a frozen battery; it may explode. Warm battery to 16C (60F)



AVOID HIGH-PRESSURE FLUIDS

Escaping fluid under pressure can penetrate the skin causing serious injury or death.

Avoid the hazard, relieve pressure before disconnecting hydraulic or other lines. Tighten all connections before applying pressure.

Search for leaks with a piece of cardboard. Protect hands and body from high pressure fluids.

If an accident occurs, see a doctor immediately. Any fluid injected into the skin must be surgically removed within a few hours or gangrene may result. Doctors unfamiliar with this type of injury should reference a knowledgeable medical source.





PREPARING TRACTOR FOR TRAILER MIXER

POSITIONING DRAWBAR

IMPORTANT: Drive components can be damaged from excessive speed. Do not operate tractor at speeds in excess of recommended PTO rpm .

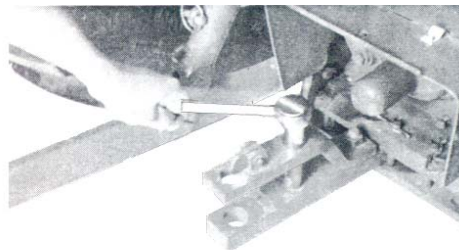

This feed mixer is equipped with a 540 RPM driveline. Match tractor PTO with the feed mixer driveline.

IMPORTANT: To prevent driveline damage, adjust tractor drawbar to recommended setting. Disengage tractor PTO before turning.

Remove clevis if equipped. Turn offset drawbar down.

Adjust drawbar length:

PTO SPEED	DIMENSION (A)
540 RPM	16 inches (406 mm)

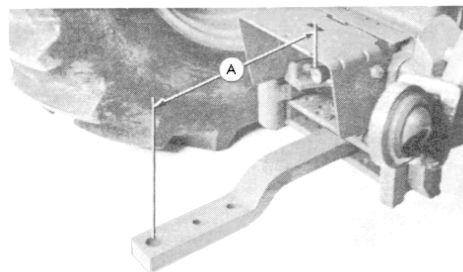



SAFETY DECAL CARE

Keep safety decals and signs clean and legible at all times.

Replace safety decals and signs that are missing or have become illegible.

Replaced parts that displayed a safety sign should also display the current sign.

Safety decals or signs are available from your dealer or the ROTO-MIX manufacturing plant.

How to Install Safety Decals:

Be sure that the installation area is clean and dry.

Decide on the exact position before you remove the backing paper.

Remove the smallest portion of the split backing paper.

Align the decal over the specified area and carefully press the small portion with the exposed sticky backing in place.

Slowly peel back the remaining paper and carefully smooth the remaining portion of the decal in place.

Small air pockets can be pierced with a pin and smoothed out using the piece of decal backing paper.



IMPORTANT
ALWAYS REDUCE ENGINE SPEED
TO IDLE BEFORE ENGAGING
AND DISENGAGING PTO.
DISENGAGE TRACTOR PTO
BEFORE TURNING.

440801





REMEMBER

Your best assurance against accidents is a careful and responsible operator. If there is any portion of this manual or function you do not understand, contact your dealer or the ROTO-MIX plant.

BEFORE OPERATION:

Carefully study and understand this manual.

Do not wear loose-fitting clothing which may catch in moving parts.

Always wear protective clothing and substantial shoes.

Keep wheel lug nuts or bolts tightened to specified torque.

Assure that agricultural implement tires are inflated evenly.

Give the unit a visual inspection for any loose bolts, worn parts or cracked welds, and make necessary repairs. Follow the maintenance safety instructions included in this manual.

Be sure that there are no tools lying on or in the mixer/feeder.

Do not use the unit until you are sure that the area is clear, especially children and animals.

Because it is possible that this mixer/feeder may be used in dry areas or the presence of combustibles, special precautions should be taken to prevent fires and fire fighting equipment should be readily available.

Don't hurry the learning process or take the unit for granted. Ease into it and become familiar with your new mixer/feeder.

Practice operation of your mixer/feeder and its attachments. Completely familiarize yourself and other operators with its operation before using.

Securely attach to towing unit. Use a high strength, appropriately sized hitch pin with a mechanical retainer.

Do not allow anyone to stand between the tongue or hitch and the towing vehicle when backing up to the mixer/feeder.



DURING OPERATION:

Beware of bystanders, **particularly children!** Always look around to make sure that it is safe to start the engine of the towing vehicle or move the unit. This is particularly important with higher noise levels and quiet cabs, as you may not hear people shouting.

NO PASSENGERS ALLOWED - Do not carry passengers anywhere on, or in, the tractor or equipment, except as required for operation.

Keep hands and clothing clear of moving parts.

Do not clean, lubricate or adjust your mixer/feeder while it is moving.

Be especially observant of the operating area and terrain - watch for holes, rocks or other hidden hazards. Always inspect the area prior to operation.

Do not operate near the edge of drop-offs or banks.

Do not operate on steep slopes as overturn may result.

Operate up and down (not across) intermediate slopes. Avoid sudden starts and stops.

Pick the levellest possible route when transporting across fields. Avoid the edges of ditches or gullies and steep hillsides.

Be extra careful when working on inclines.

Periodically clear the equipment of brush, twigs or other materials to prevent buildup of dry combustible materials.

Maneuver the tractor or towing vehicle at safe speeds.

Avoid overhead wires or other obstacles. Contact with overhead lines could cause serious injury or death.

Avoid loose fill, rocks and holes; they can be dangerous for equipment operation or movement. Allow for unit length when making turns.

Do not walk or work under raised components or attachments unless securely positioned and blocked.

Keep all bystanders, pets and livestock clear of the work area.

Operate the towing vehicle from the operator's seat only.

Never stand alongside of the unit with engine running. Never attempt to start engine and/or operate machine while standing alongside of unit.



DURING OPERATION (CONT.)

Never leave running mixer/feeder unattended.

As a precaution, always recheck the hardware on mixer/feeder following every 100 hours of operation. Correct all problems. Follow the maintenance safety procedures.



FOLLOWING OPERATION:

Following operation, or when unhitching, stop the tractor or towing vehicle, set the brakes, disengage the PTO and all power drives, shut off the engine and remove the ignition keys.

Store the unit in an area away from human activity.

Do not park equipment where it will be exposed to livestock for long periods of time. Damage and livestock injury could result.

Do not permit children to play on or around the stored unit.

Make sure parked machine is on a hard, level surface and engage all safety devices.

Wheel chocks may be needed to prevent unit from rolling.



HIGHWAY AND TRANSPORT OPERATIONS:

Adopt safe driving practices:

Keep the brake pedals latched together at all times. **Never use independent braking with machine in tow as loss of control and/or upset of unit can result.**

Always drive at a safe speed relative to local conditions and ensure that your speed is low enough for an emergency stop to be safe and secure. Keep speed to a minimum.

Reduce speed prior to turns to avoid the risk of overturning.

Avoid sudden uphill turns on steep slopes.

Always keep the tractor or towing vehicle in gear to provide engine braking when going downhill. Do not coast.

Do not drink and drive.



HIGHWAY AND TRANSPORT OPERATIONS (CONT.):

Comply with state and local laws governing highway safety and movement of farm machinery on public roads.

Use approved accessory lighting, flags and necessary warning devices to protect operators of other vehicles on the highway during daylight and nighttime transport.

The use of flashing amber lights is acceptable in most localities. However, some localities prohibit their use. Local laws should be checked for all highway lighting and marking requirements.

When driving the tractor and mixer/feeder on the road or highway under 20 MPH (40 KPH) at night or during the day, use flashing amber warning lights and a slow moving vehicle (SMV) identification emblem.

Plan your route to avoid heavy traffic.

Be a safe courteous driver. Always yield to oncoming traffic in all situations, including narrow bridges, intersections, etc.

Be observant of bridge loading ratings. Do not cross bridges rated lower than the gross weight at which you are operating.

Watch for obstructions overhead and to the side while transporting.

Always operate mixer/feeder in a position to provide maximum visibility at all times. Make allowances for increased length and weight of the mixer/feeder when making turns, stopping the unit, etc.



PERFORMING MAINTENANCE:

Good maintenance is your responsibility. Poor maintenance is an invitation to trouble.

Make sure there is plenty of ventilation. Never operate the engine of the towing vehicle in a closed building. The exhaust fumes may cause asphyxiation.

Before working on the mixer/feeder, stop the towing vehicle, set the brakes, disengage the PTO and all power drives, shut off the engine and remove the ignition keys.

Be certain all moving parts on attachments have come to a complete stop before attempting to perform maintenance.

Always use a safety support and block the wheels. Never use a jack to support the machine.



PERFORMING MAINTENANCE (CONT.):

Always use the proper tools or equipment for the job at hand.

Use extreme caution when making adjustments.

Never use your hands to locate hydraulic leaks on attachments. Use a small piece of cardboard or wood. Hydraulic fluid escaping under pressure can penetrate the skin.

When disconnecting hydraulic lines, shut off hydraulic supply and relieve all hydraulic pressure.

Openings in the skin and minor cuts are susceptible to infection from hydraulic fluid. If injured by escaping hydraulic fluid, see a doctor at once. Gangrene can result. Without immediate treatment, serious infection and reactions can occur.

Replace all shields and guards after servicing and before moving.

After servicing, be sure all tools, parts and service equipment are removed.

Do not allow grease or oil to build up on any step or platform.

Never replace hex bolts with less than grade five (5) bolts unless otherwise specified.

Where replacement parts are necessary for periodic maintenance and servicing, genuine factory replacement parts must be used to restore your equipment to original specifications. ROTO-MIX will not claim responsibility for use of unapproved parts and/or accessories and other damages as a result of their use.

If equipment has been altered in any way from original design, ROTO-MIX does not accept any liability for injury or warranty.

A fire extinguisher and first aid kit should be kept readily accessible while performing maintenance on this mixer/feeder.

READ THE FOLLOWING BEFORE WELDING ON THIS MIXER

When welding on your mixer/feeder, do not allow the current to flow through the ball bearings or the roller chains. Ground directly to the item being welded.

Always disconnect the scale instrumentation from the weigh bars or load cells and the power source. Be sure the current does not pass through weigh bars or load cells or scale indicator. The alternator should always be disconnected if the mixer/feeder is not disconnected from the towing vehicle.

LOADING INSTRUCTIONS & PRECAUTIONS

- A. Visually inspect mixer before each load.
- B. Do not overload the mixer. Mixer capacity is determined by weight. An overloaded mixer will not mix correctly, and will pull harder, which could damage your tractor.
- C. Load hay first with machine running: **TRACTOR RPM SPEED.**
- D. Add balance of grain and/or commodities, keeping more fragile ingredients toward the end of the loading sequence as possible.
- E. Load silage, green chop and/or other high moisture products.
- F. Load molasses, animal fat, and/or other liquid supplements last.
- G. Allow mixer three to four minutes to complete mixing after last ingredient is added. (**NOTE:** this time will vary, and could be longer under certain conditions.)
- H. For best results, off load mixed feed at as high a **RPM** as possible, and with the door as open as possible. The last half must be fed off at high RPM, to ensure even feed flow and clean out.

HAY PREPARATION:

- 1. SMALL BALES-(60 to 150 lbs., 2 or 3 wire)
 - A. Remove twine or wire from bales.
 - B. Load bales in mixer.
 - 2. LARGE SQUARE BALES-(3' x 4' x 8' or 4' x 4' x 8')
 - 3. ROUND BALES
 - A. Remove twine or wrapping.
 - B. Load bale in mixer.
- A. Remove twine or wrapping.
 - B. Load bale in mixer.

Maintenance & Lubrication

Continued

Planetary Gearbox

Every three months lubricate fitting with five pumps of grease. To get to the fitting you must remove the 4" plastic plug at base of vertical screw assembly by rotating it until it faces the back of the mixer.

Oil Change

The first oil change should take place after you've been operating mixer for one month. After this, oil change is only necessary once a year.

Oil Capacity

4 1/2 Gallon in gear casing, 1/2 Gallon in oil reservoir

Guidelines for oil change:

- Remove drain plug, allow oil to completely drain, then replace the plug.
- Remove 4" plastic plug at bottom of vertical screw to access fill plug on side of the gearbox.
- Fill gearbox through plug using a hose and oil pump.
- Allow time for oil to drain into gearsets.
- Oil level should be near the the middle of the visual oil gauge.

REPAIR PARTS TABLE OF CONTENTS

	PAGE NO.
MIXER DRIVE COMPONENTS	18
FRAME & RELATED PARTS	20
SCALE COMPONENTS.....	22
DISCHARGE DOOR HYDRAULICS	23
TUB & AUGER ASSEMBLY.....	24

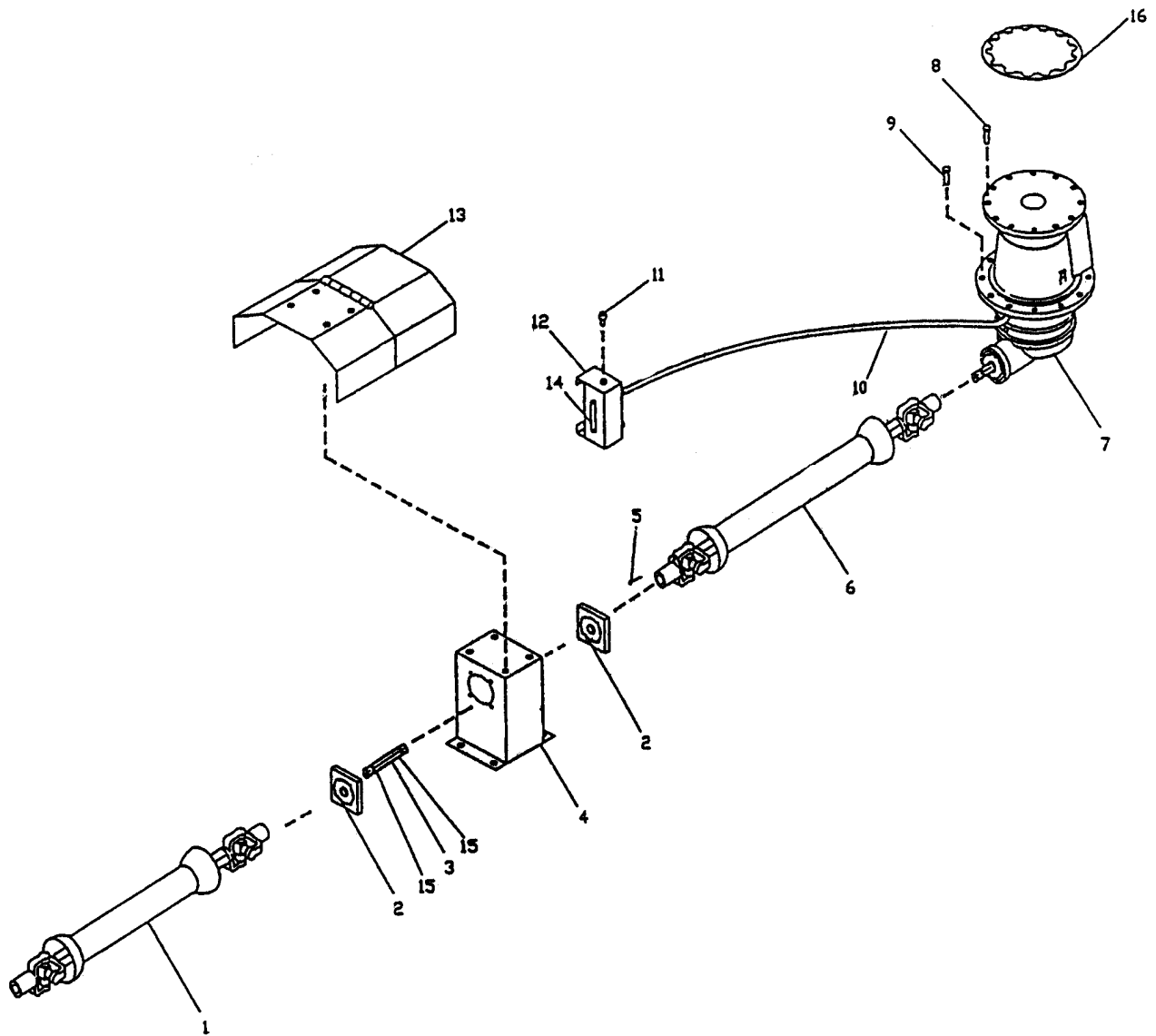

PTO Drivelines, Transfer Box, & Planetary Gearbox

1	MBB401	Complete PTO.....	1
2	MBB402	4 Bolt bearing, cast 1-3/4" B, relube, 4-1/8" hole center.....	2
3	MBB403	Splined carrier shaft, 1-3/4" x 18" splined both ends.....	1
4	MBB404	Single speed transfer box.....	1
5	MBB405-A	Shear bolt M 8 x 55 top locknut.....	1
	MBB405-B	M 8 top locknut.....	1
6	MBB406	Complete PTO.....	1
7	MBB407	Planetary Drive Gearbox.....	1
8	MBB408	M16 - 20 x 60 HHCS, Class 8.8 blk.....	15
9	MBB409-A	5/8-11-3" HHCS, grd 8.....	15
	MBB409-B	5/8-11 top locknut.....	15
10	MBB410	1/2 low pressure hose, no ends.....	1
11	MBB411	Filler cap, planetary reservoir.....	1
12	MBB412	Oil reservoir.....	1
13	MBB413	Transfer box PTO cover, 10 ga x 18" x 22".....	1
14	MBB414	3/8" ID, clear vinyl tubing.....	1
15	MBB415	Lock collar, 1-3/4 B, single split.....	2
16	MBB416	3/8" spacer ring.....	1

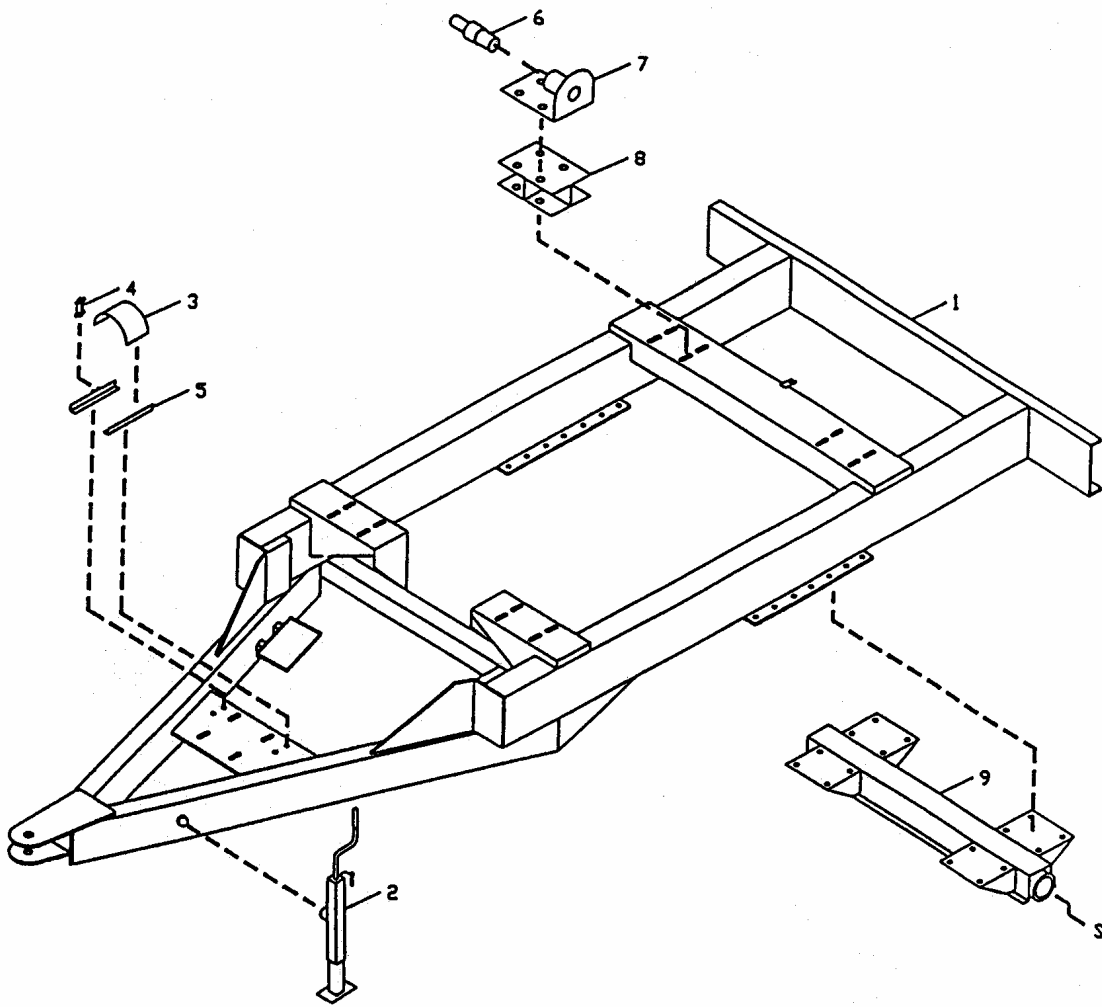

SEE PAGES 27-29

Frame

1	MBF101	Frame assembly	1
2	MBF102	10,000 Lb. jack	1
3	MBF103	2-Speed gearbox rear shield assembly	1
4	MBF104	2-Speed gearbox small rubber shield latch	1
5	MBF105	2-Speed gearbox angles	2
6		Truck mount w/b 2-1/8" OD	4
7	MBF107	Scale bracket, 4 Pt, flat base	4
8	MBF108	Riser block assembly, SRM, 4"	4
9	MBF109	Axle assembly	1
10	MBF110-A	Spindle assy, 3"x17 3/8", cap, nut, washer & cotter	2
	MBF110-B	Spindle, complete assembly	2
11	MBF111-A	Grease seal, 4" OD	2
	MBF111-B	Grease seal, 3.25" ID x 4.125 OD	2
12	MBF112-A	Inner bearing cone	2
	MBF112-B	Inner bearing cone, 2.5 ID	2
13	MBF113-A	Inner bearing cup	2
	MBF113-B	Inner bearing cup	2
14	MBF114-A	Wheel stud, 5/8-18 NF	16
	MBF114-B	Wheel stud, 3/4-16 x 2-3/4" for 10 bolt hub	16
15	MBF115-A	Wheel hub, 8 bolt, 10,000 lb. assembly	2
	MBF115-B	Wheel hub, 8 bolt, 8,000 lb. assembly	2
16	MBF116-A	Wheel nut, 5.8-28 NF	16
	MBF116-B	Wheel nut, flanged, 3/4-16, ZP	16
17	MBF117	Outer bearing cup	2
18	MBF118	Outer bearing cone	2
19	MBF119	Spindle washer, 1-1/16" ID x 2-1/8" OD x 1/4"	2
20	MBF120	Spindle cotter, 3/32" x 1-1/2"	2
21	MBF121	Spindle nut, 1-14 slotted nut	1
22	MBF122	Cap, 8 bolt HD	2
23	MBF123-A	8-bolt, 14.5 wheel rim w/ 30.5 x 11 tire	2
	MBF123-B	8-bolt, wheel w/ aircraft tire, (option)	2

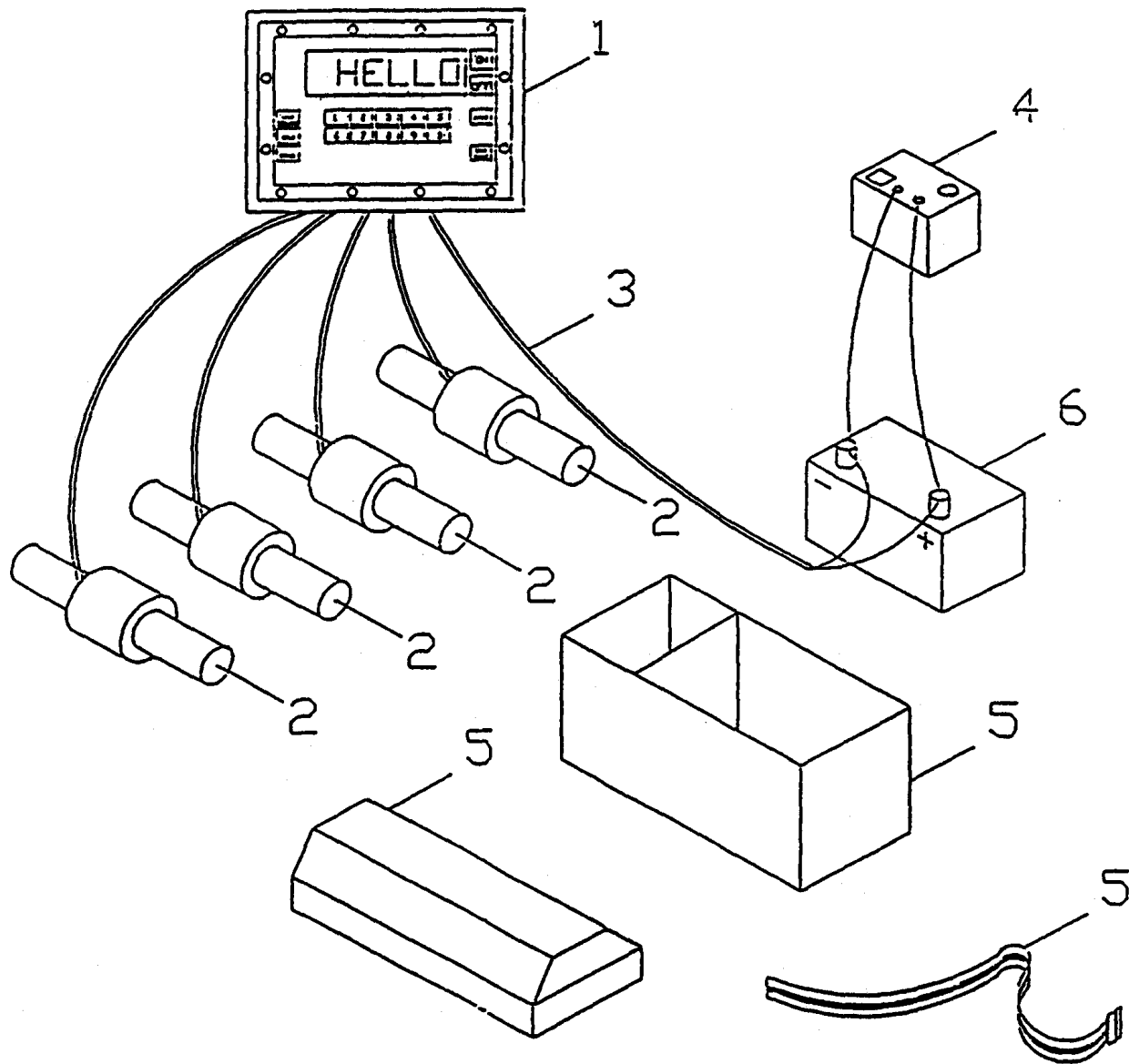

Digi-Star Electronic Scales

1	450146	Indicator EZ-2000V.....	1
2	450923	J-box, 4-pin,.....	1
3	450822	WB, 2-1/8" OD,.....	1
4	450683	Power cord, 4-pin, 20' for power pak.....	1
5	453533	2 amp battery charger, 12-v.....	1
6	357400	Plastic battery box, W/Strap, 7.5" X 11".....	1
7	980209	Battery, 12-Volt.....	1

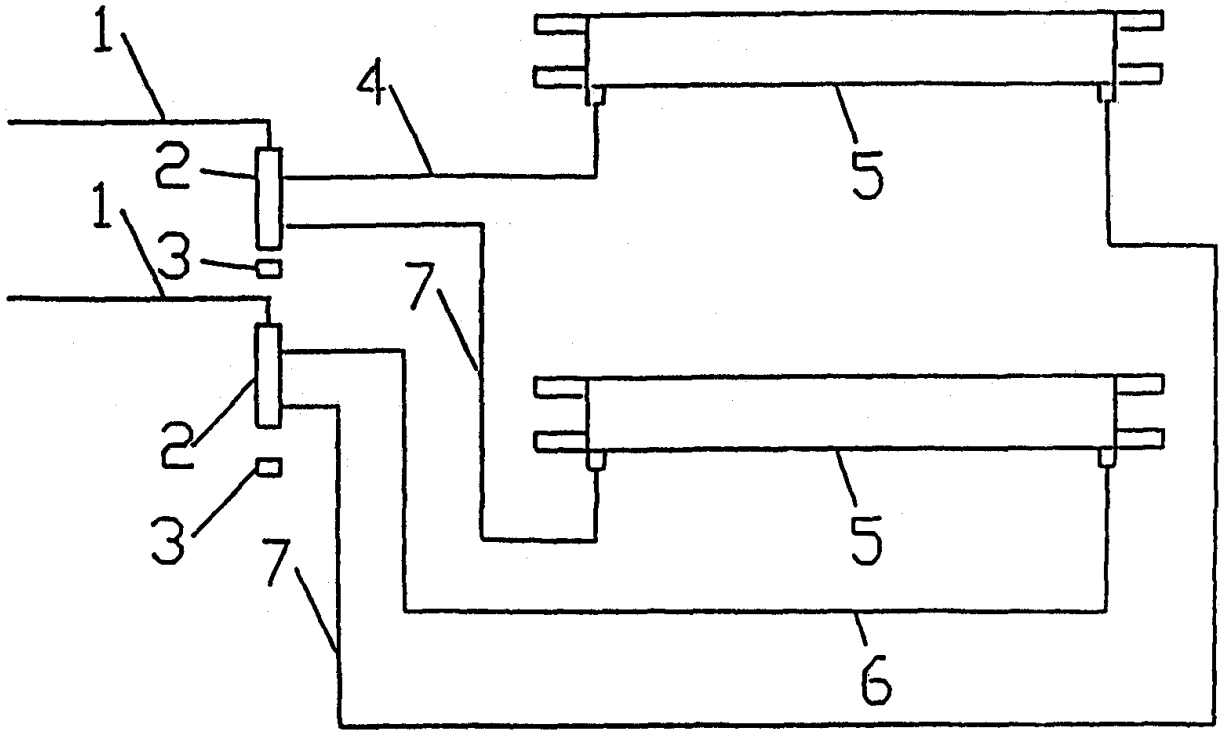

Hydraulic Cylinder Hoses for Discharge Door

1	MBD801	3/8"- 3000 PSI x 120" hydraulic hose, 1 swivel, 1 solid end.....	2
2	MBD802	Hydraulic header manifold, o-ring ports: (2) 3/4" and (2) 9/16".....	2
3	MBD803	3/4-16" o-ring plug.....	2
4	MBD804	3/8"- 3000 PSI x 39" hydraulic hose, (1) 90 degree swivel, (1) straight swivel.....	1
5	MBD805	Hydraulic cylinder, 2" x 24", 9/16-18" o-ring ports.....	2
6	MBD806	3/8"- 3000 PSI x 120" hydraulic hose, 1 swivel, 1 solid end.....	1
7	MBD807	3/8"- 3000 PSI x 127" hydraulic hose, 1 swivel, 1 solid end.....	2

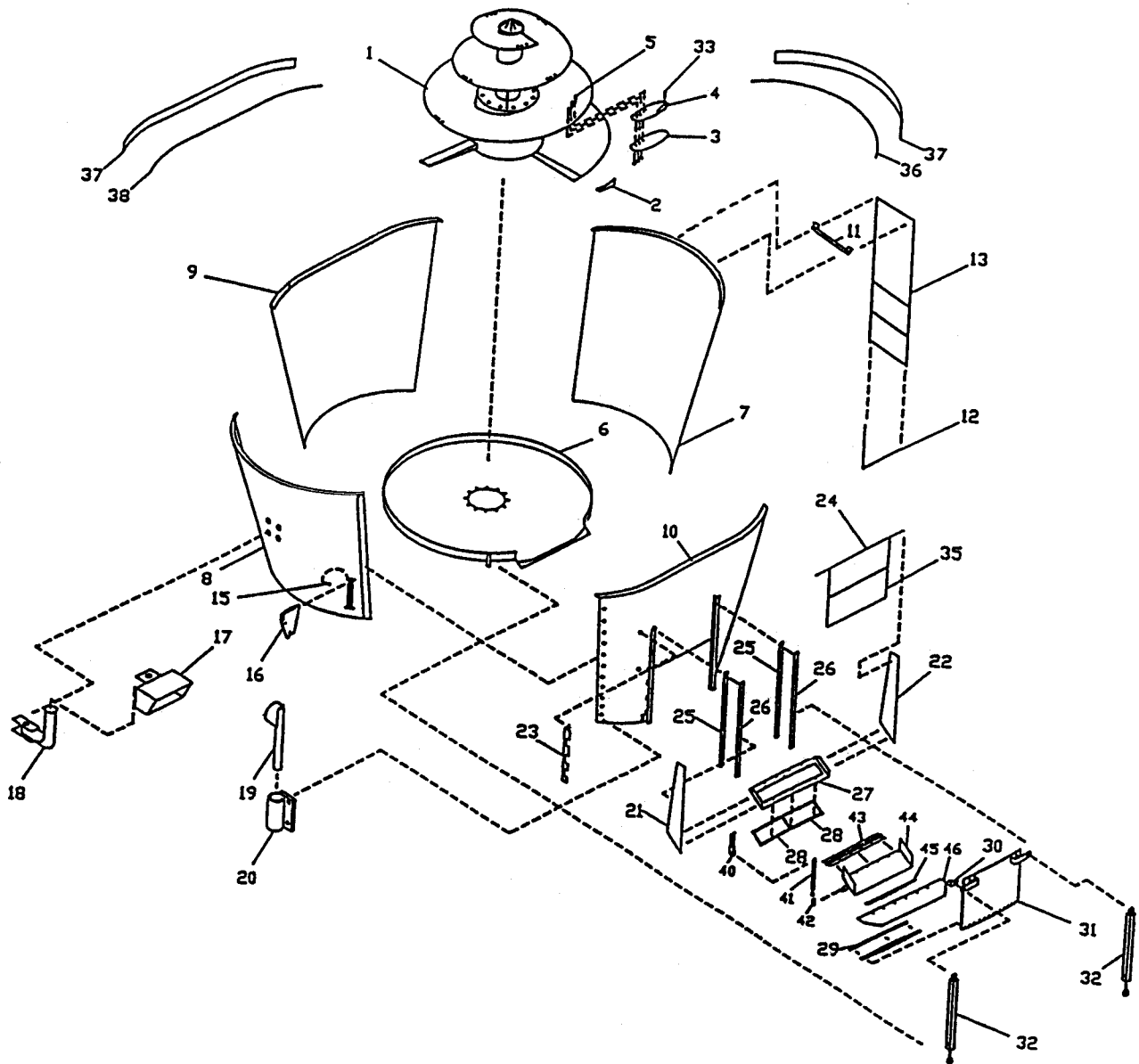

Tub, Screw Assembly

1	MBT201	Screw assembly.....	1
2	MBT202	Edge deflector.....	1
3	MBT203	Backing plate for blade.....	1
4	385007	Knife Blade, Standard.....	1
	385008	Knife Blade, Carbide.....	1
5	MBT205-A	5/8-11 x 2 1/2 " carriage HD, grd 5,.....	1
	MBT205-B	M-F 5/8 x 11 TWA nut.....	1
6	MBT206	Base plate assembly.....	1
7	MBT207	Complete Tub (not as shown) 400 sold in one piece.....	1
8	MBT208	Complete Tub (not as shown) 500 sold in one piece.....	1
9	MBT209	Complete Tub (not as shown) 600 sold in one piece.....	1
10	MBT210	Discharge door.....	1
11	MBT211	Top ladder bracket.....	1
12	MBT212	Bottom ladder bracket.....	1
13	MBT213	Ladder assembly.....	1
15	MBT215	Pin for restrictor plate.....	2
16	MBT216	Restrictor plate.....	2
17	MBT217	Swivel mount hood.....	1
18	MBT218	Swivel mount assembly.....	1
19	MBT219	Restrictor wrench.....	1
20	MBT220	Restrictor holder.....	1
21	MBT221	Discharge chute side panel 12 ga x 10" x 41 3/4, lh.....	1
22	MBT222	Discharge chute side panel 12 ga x 10" x 41 3/4, rh.....	1
23	MBT223	Vertical door gauge.....	1
24	MBT224	Chute bottom slide.....	1
25	MBT225	Door spacer strap.....	2
26	MBT226	Door guide strap.....	2
27	MBT227	Discharge Chute bottom slide.....	2
28	MBT228	Magnet.....	1
29	MBT229	Door sealing strap.....	1
30	MBT230	Vertical door Gauge.....	1
31	MBT231	Discharge door.....	1
32	MBT232-A	Hyd Cyl, 2" x 24", 9/16-18" o-ring ports.....	2
	MBT232-B	Hyd Cyl, 2" x 30", 9/16-18" o-ring ports.....	2
33	MBT233	Carriage sq, HD, grd 5.....	5
35	MBT235	Rubber swing shield.....	1
36	MBT236	Rubber extension attachment strap.....	2
37	MBT237	Rubber extension.....	2
40	MBT240	Upper cylinder bracket for slide chute.....	1
41	MBT241	Hyd Cyl, 2" x 12", 9/16-18 o-ring ports.....	1
42	MBT242	Slide chute cyl strap.....	1
43	MBT243	Hinge, 180 x .500 x 8" x 42".....	1
44	MBT244	Flip down discharge chute assembly.....	1
45	MBT245	Conveyor strap for rubber seal.....	1
46	MBT246	Rubber spout extension, 1/4" rubber x 5" x 55".....	1