



# **810 SILAGE PRO BUNK FACER**

## **OPERATOR'S MANUAL INSTALLATION INSTRUCTIONS AND PARTS**

**ROTO-MIX  
P.O. Box 1724  
2205 E. Wyatt Earp Blvd.  
Dodge City, Kansas 67801  
(620) 225-1142**

# WARRANTY

ROTO-MIX LLC, warrants to the original purchaser all products manufactured by it to be free from defects in material and workmanship under normal use and service. ROTO-MIX's obligation under this warranty is limited to repairing or replacing, as the company may elect, free of charge and without charge for installation, at the place of business of a dealer or distributor authorized to handle the equipment covered by this warranty or at a ROTO-MIX plant, any parts that prove, in the company's judgment, to be defective in material and workmanship within one (1) year after delivery to the original purchaser, and still owned by the original purchaser.

It is a condition of this warranty that the original purchaser must fill out the warranty card furnished by ROTO-MIX and that it be returned to ROTO-MIX and be recorded in ROTO-MIX's owner file for this warranty to be valid. In the event an owner's card is not on file at the ROTO-MIX office, the warranty period will extend only from date equipment was picked up or delivered from the ROTO-MIX plant.

It is a condition of this warranty that if within the aforesaid period of time, said equipment, product or parts are determined by the original purchaser to be defective as herein provided, then such defective part or parts must be delivered by or through a dealer and/or distributor to ROTO-MIX at its factory with transportation prepaid or warranty shall be of no force or effect and shall be waived by the purchaser. If ROTO-MIX, or its duly authorized representative, shall find that such returned part or parts are defective and such defects, or defect, are included in and covered by said warranty, then such defective part or parts shall promptly be replaced without charge to the purchaser, F.O.B. the ROTO-MIX plant.

This warranty shall not apply to any item, manufactured in whole or in part by ROTO-MIX, which shall have been operated in a manner not recommended by ROTO-MIX nor which shall have been repaired, altered, neglected, tampered with, or used in anyway which in the company's opinion adversely affects its performance.

This warranty shall in no way make ROTO-MIX liable to anyone for personal injuries or damages, loss of time, or expense of any kind either direct or indirect resulting from part failure or defect.

This warranty is subject to acts of God, fire and existing conditions of supply and demand, or production, or ability or inability to deliver, or for any other valid reason beyond the reasonable control of ROTO-MIX, to obtain materials, manufactured replacement parts, or make delivery thereof.

No distributor, dealer, agent, or employee of ROTO-MIX is authorized to extend any other or further express or implied warranty or incur any additional obligation on ROTO-MIX's behalf in connection with the sale of this product.

ROTO-MIX reserves the right to make changes in design, or additions to, or improvements in its equipment without obligation to install such changes, additions, or improvements in equipment previously manufactured.

# TABLE OF CONTENTS

	PAGE NO.
WARRANTY -----	2
TABLE OF CONTENTS -----	3
OPERATOR QUILIFICATIONS -----	4
LUBRICATION -----	4
SPECIFICATIONS -----	5
SAFETY INFORMATION-----	5-9
REPAIR PARTS-----	11-14

## **OPERATOR QUALIFICATIONS**

Operation of this bunk facer shall be limited to competent and experienced persons. In addition, anyone who will operate or work around a bunk facer must use good common sense. In order to be qualified, he or she must also know and meet all other qualifications, such as:

1. Some regulations specify that no one under the age of sixteen (16) may operate power machinery. It is your responsibility to know what these regulations are in your area and/or situation.
2. Current OSHA regulations state in part: At the time of initial assignment and at least annually thereafter, the employer shall instruct **EVERY** employee in the safe operation and servicing of all equipment with which the employee is, or will be involved.
3. Unqualified persons are to **STAY OUT OF THE WORK AREA.**
4. A person who has not read and understood all operating and safety instructions is not qualified to operate the machinery.

## **FAILURE TO READ THIS BUNK FACER MANUAL AND ITS SAFETY INSTRUCTIONS IS A MISUSE OF THE EQUIPMENT.**

## **OPERATING THE BUNK FACER**

Make cuts from the top of the bunk to the bottom.

Cut depth and speed will be limited by the amount of power available from the tractor you are using.

Never try to cut a depth greater than half the diameter of the bunk facer, the motor may stall and you may cause serious damage to the unit.

## **SERVICE & MAINTENANCE**

Grease the left hand bearing every 10 hours of operation.

Remove excess material built-up from bunk facer after each use.

## SPECIFICATIONS

CUTTING WIDTH.....	96”
TOTAL WIDTH .....	101”
UNIT WEIGHT APPRO.....	835 lbs
HYDRAULIC PRESSURE REQUIRED .....	2,500—2,800 PSI
HYDRAULIC FLOW REQUIRED .....	15 TO 25 GPM
NUMBER OF KNIVES.....	46

## SAFETY FIRST

**REMEMBER:** The careful operator is the best operator. Most accidents are caused by human error. Certain precautions must be observed to prevent the possibility of injury or death.



**DO NOT ALLOW PERSONNEL OTHER THAN THE QUALIFIED OPERATOR NEAR THE MACHINE.**



**NEVER START MACHINE UNTIL ALL GUARDS AND SAFETY SHIELDS ARE IN PLACE.**



**DO NOT CLEAN, ADJUST OR LUBRICATE THE MACHINE WHILE IT IS IN MOTION.**



**BEFORE STARTING TRACTOR ENGINE, MAKE SURE UNIT IS ATTACHED TO THE TRACTOR PROPERLY.**



### **OPERATING PRECAUTIONS & INSTRUCTIONS:**

- A. Check to see that no obstructions are present in the facer prior to start up.
- B. Before making contact with the bunk material, run the facer empty and check all operations.
- C. Do not overload the bunk facer, as the hydraulic system may stall and unit damage may occur.
- D. Use common sense when operating.



## EQUIPMENT SAFETY GUIDELINES

Safety of the operator is one of the main concerns in designing and developing a new piece of equipment. Designers and manufactures build in as many safety features as possible. However, every year many accidents occur which could have been avoided by a few seconds of thought and a more careful approach to handling equipment. You, the operator, can avoid many accidents by observing the following precautions in this section. To avoid personal injury, study the following precautions and insist those working with you, or for you, follow them.

In order to provide a better view, certain photographs or illustrations in this manual may show an assembly with a safety shield removed. However, equipment should never be operated in this condition. Keep all shields in place. If shield removal becomes necessary for repairs, replace the shield prior to use.

Replace any CAUTION, WARNING, DANGER or instruction safety decal that is not readable or is missing. Location of such decals are indicated in this manual.

Do not attempt to operate this equipment under the influence of drugs or alcohol.

Review the safety instructions with all users annually.

This equipment is dangerous to children and persons unfamiliar with its operation. The operator should be a responsible adult familiar with farm machinery and trained in this equipment's operations. Do not allow persons to operate or assemble this unit until they have read this manual and have developed a thorough understanding of the safety precautions and of how it works.

To prevent injury or death, use a tractor equipped with a Roll Over Protective System (ROPS). Do not paint over, remove or deface any safety signs or warning decals on your equipment. Observe all safety signs and practice the instructions on them.

Never exceed the limits of a piece of machinery, in its ability to do a job, or to do so safely, if in question - **DON'T TRY IT.**



## LIGHTING AND MARKING

It is the responsibility of the customer to know the lighting and marking requirements of the local highway authorities and to install and maintain the equipment to provide compliance with the regulations. Add extra lights when transporting at night or during periods of limited visibility.



## **AVOID HIGH-PRESSURE FLUIDS**

Escaping fluid under pressure can penetrate the skin causing serious injury or death.

Avoid the hazard relieving pressure before disconnecting hydraulic or other lines. Tighten all connections before applying pressure.

Search for leaks with a piece of cardboard. Protect hands and body from high pressure fluids.



If an accident occurs, see a doctor immediately. Any fluid injected into the skin must be surgically removed within a few hours or gangrene may result. Doctors unfamiliar with this type of injury should reference a knowledgeable medical source.



## **SAFETY DECAL CARE**

Keep safety decals and signs clean and legible at all times.

Replace safety decals and signs that are missing or have become illegible.

Replaced parts that displayed a safety sign should also display the current sign.

Safety decals or signs are available from your dealer or the ROTO-MIX manufacturing plant.

### **How to Install Safety Decals:**

Be sure that the installation area is clean and dry.

Decide on the exact position before you remove the backing paper.

Remove the smallest portion of the split backing paper.

Align the decal over the specified area and carefully press the small portion with the exposed sticky backing in place.

Slowly peel back the remaining paper and carefully smooth the remaining portion of the decal in place.

Small air pockets can be pierced with a pin and smoothed out using the piece of decal backing paper.



## **REMEMBER**

**Your best assurance against accidents is a careful and responsible operator. If there is any portion of this manual or function you do not understand, contact your dealer or the ROTO-MIX plant.**

### **BEFORE OPERATION:**

Carefully study and understand this manual.

Do not wear loose-fitting clothing which may catch in moving parts.

Always wear protective clothing and substantial shoes.

Assure that agricultural implement tires are inflated evenly.

Give the unit a visual inspection for any loose bolts, worn parts or cracked welds, and make necessary repairs.

Be sure that there are no tools lying on or in the bunk facer.

Do not use the unit until you are sure that the area is clear, especially children and animals.

Don't hurry the learning process or take the unit for granted. Ease into it and become familiar with your new bunk facer.

Practice operation of your bunk facer. Completely familiarize yourself and other operators with its operation before using.



### **DURING OPERATION:**

Beware of bystanders, **particularly children!** Always look around to make sure that it is safe to start the bunk facer or move the unit. This is particularly important with higher noise levels and quiet cabs, as you may not hear people shouting.

**NO PASSENGERS ALLOWED** - Do not carry passengers anywhere on, or in, the tractor or equipment, except as required for operation.

Keep hands and clothing clear of moving parts.

Do not clean, lubricate or adjust your bunk facer while it is moving.



## **DURING OPERATION (CONT.)**



Be especially observant of the operating area and terrain - watch for holes, rocks or other hidden hazards. Always inspect the area prior to operation.

**Do not** operate near the edge of drop-offs or banks.

**Do not** operate on steep slopes as overturn may result.

**Operate** up and down (not across) intermediate slopes. Avoid sudden starts and stops.

Be extra careful when working on inclines.

Periodically clear the equipment of brush, twigs or other materials to prevent buildup of dry combustible materials.

Avoid overhead wires or other obstacles. Contact with overhead lines could cause serious injury or death.

Do not walk or work under raised components or attachments unless securely positioned and blocked.

Keep all bystanders, pets and livestock clear of the work area.

Operate the bunk facer from the operator's seat only.

Never stand alongside of the unit with engine running. Never attempt to start engine and/or operate machine while standing alongside of unit.

Never leave running bunk facer unattended.

As a precaution, always recheck the hardware on bunk facer following every 100 hours of operation. Correct all problems.

### **FOLLOWING OPERATION:**

Following operation, set the brakes, disengage all power drives, shut off the engine and remove the ignition keys.

Store the unit in an area away from human activity.

Do not park equipment where it will be exposed to livestock for long periods of time. Damage and livestock injury could result.

Do not permit children to play on or around the stored unit.

Make sure parked machine is on a hard, level surface and engage all safety devices.

Wheel chocks may be needed to prevent unit from rolling.



**PARTS PAGES  
TABLE OF CONTENTS**

**PAGE NO.**

**BUNK FACER PARTS .....12-13**

**BUNK FACER ATTACHMENTS..... 14**

# 810 SILAGE PRO BUNK FACER

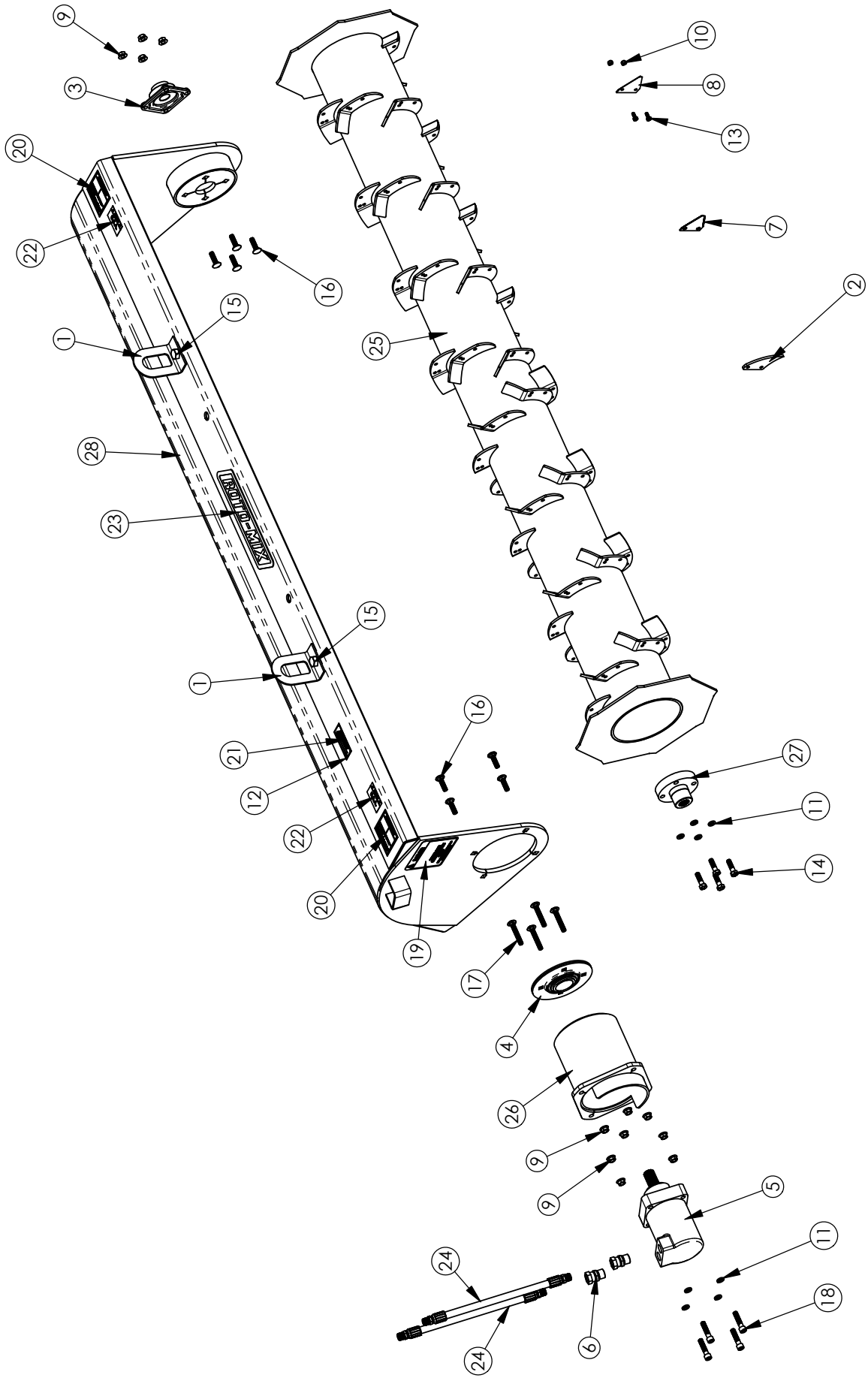

## 810 SILAGE PRO BUNK FACER

ITEM #	QTY.	PART #	DESCRIPTION
1	2	110789	LIFT BRACKET 4" x 7-1/16"
2	46	110883	HOOK TYPE KNIFE
3	1	340421	BEARING, 1-1/4" SHAFT- 4 BOLT FLANGE
4	1	341635	BRG., RA 2 3/16 ID FLANGEITE UNIT
5	1	360026	HYD. MOTOR, 32.7 CID, 14 TOOTH SPLINE
6	2	368128	STR. ADPT 1-1/16 MOR x 1/2 FPSW
7	46	385000	SERRATED SICKLE SECTION
8	46	385002	KNIFE SECTION - NO SERRATION FINISH 20H
9	12	400114	HEX NUT, SERRATED FLANGE #5 Pltd., 1/2"-13
10	92	401105	HEX NYLOC NUT #5 Pltd., 5/16"-18
11	8	402008	LOCK WASHER, Pltd., 1/2"
12	4	404500	DRIVE SCREW
13	92	405627	HHCS #5 Pltd 5/16" x 3/4"
14	4	405704	HHCS #5 PLTD, 1/2" x 1 3/4" LG
15	2	405777	HHCS #5 PLTD 3/4" 10 x 1 1/2"
16	8	407103	1/2"-13 X 2" CARRIAGE BOLT
17	4	407108	1/2"-13 X 3" CARRIAGE BOLT
18	4	409067	1/2 x 2 1/4 SHCS
19	2	440827	DECAL - DANGER: ROTATING AUGERS
20	2	440833	DANGER PINCH POINT 4"x 4"
21	1	440842-M	SERIAL NO. PLATE, 1-7/8" x 4"
22	2	440844	DECAL- (MADE IN USA)
23	1	440890-S	DECAL - ROTO-MIX - 14 3/4" x 3 11/16"
24	2	781312	HYD HOSE 1/2" x 104", 1/2"MP ENDS
25	1	810567	KNIFE ROTOR W/A
26	1	810571	MOTOR MOUNT HOUSING W/A
27	1	810573	DRIVE HUB W/A
28	1	810581	810 SILAGE FRAME W/A (UNIV.)

# 810 SILAGE PRO BUNK FACER MOUNTING BRACKETS

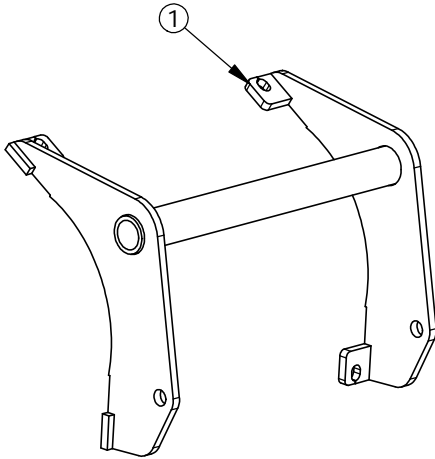

ITEM #	PART #	DESCRIPTION
1	710018	Manitou Tele-Handler Style Attachment
2	710019	JCB Tele-Handler Style Attachment
3	710025	JCB (400) Tele-Handler Style Attachment
4	710021	John Deere (3400) Tele-Handler Style Attachment
5	710024	Bobcat 863 Skid Loader Style Attachment
6	710022	Caterpillar TH-82 Loader Style Attachment
7	710026	Caterpillar TH-300 Loader Style Attachment

